



AURA

— GAS CONTROLS —



AEROSPACE • CHEMICAL • ELECTRONICS/PHOTOVOLTAIC
ENERGY • PETROCHEMICAL • PHARMACEUTICAL



Instrumentation Product Guide

WWW.AURACONTROLS.COM

ADC3180E - REVISED 2.21.2012

AURA

GAS CONTROLS

AURA Headquarters
Virginia Beach, Virginia



AURA Gas Controls' innovative regulator products are the culmination of more than a century of analytical and gas management experience. Systems and equipment are designed for use in the petrochemical, medical, pharmaceutical, fiber optics, and aerospace industries as well as for semiconductor, instrumentation, energy and systems integration applications.

Constructed of the highest quality materials, each AURA device is individually tested to meet the most demanding requirements. Our ISO 9001 quality management system ensures product quality and conformance to customer requirement. The heart of AURA's **Lifetime Warranty** is its encapsulated seat design. The first of its kind in the instrumentation industry, the encapsulated seat filters particles and debris which could cause seat failure and unnecessary downtime.

All of the AURA products are manufactured and assembled in the United States. In addition to its U.S. headquarters, AURA also has facilities in South America, Europe and Asia. With such vast worldwide representation, AURA Gas Controls is the perfect partner for delivering solutions on time and under budget on an international scale.

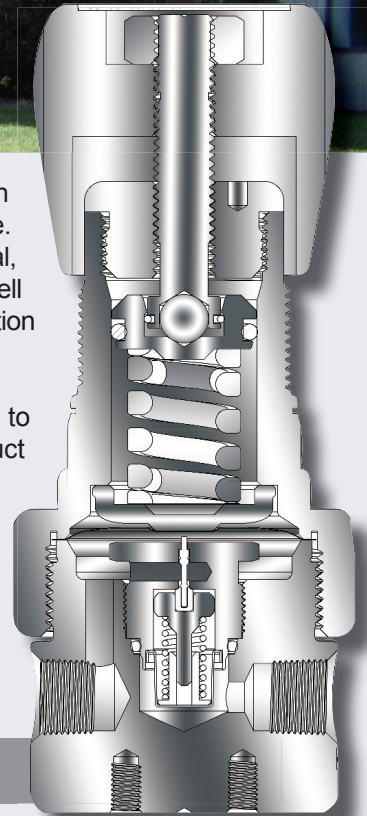

AURA Instrumentation Regulators Feature:

Encapsulated Seat



Long product life is guaranteed with AURA's encapsulated seat design in which a patented 10-micron stainless filter cap surrounds the soft seat material. The capsule filter has 800% more surface area than the average pressed-in disc filter, ensuring optimum flow capacity throughout the life of the filter. Longer life means less downtime. Additionally, seat failure caused by repetitive loading is all but eliminated by the capsule's positive stop design. This makes the AURA seat technology an ideal choice for test equipment and high-cycle life applications.

Precise Manufacturing



AURA products have metal-to-metal seals yielding helium leak rates as low as 1×10^{-9} He cc/sec. This is ideal when delivering toxic or poisonous gases into laboratory environments. Standard surface finishes of 4-25 Ra minimize reactivity and facilitate efficient purging for critical analyzer and process applications. AURA's proprietary machining process provides consistent tolerances on all threaded surfaces ensuring ease of fit-up every time. This simplifies the job for the panel builder or integrator, shortening lead-times and improving profitability. Tight tolerances improve weld integrity of tube stubs and face-seal adapters to the body, minimizing the risk of crevice corrosion in the heat-affected zone. Engineers are assured that AURA's ISO 9000-2008 systems deliver quality they can rely on.



Cleanroom Assembly

AURA strives to manufacture components with the highest degree of quality available in the industry. Most products are cleanroom-assembled at no additional cost or premium.

Lifetime Warranty

At AURA Controls we believe in the quality of our design and manufacturing processes so much that our products are backed by a Lifetime Warranty.



AURA Product Recommended Industry Applications



EX1 Single Stage Regulator

Recommended Industries: Chemical, Oil and Gas, Energy, Aerospace, Pharmaceutical, Electronics/Photovoltaics, OEM



EX2 Dual Stage Regulator

Recommended Industries: Energy, Pharmaceutical, OEM



EXB Back Pressure Regulator

Recommended Industries: Chemical, Oil and Gas, Aerospace, Pharmaceutical, Electronics/Photovoltaics



EXC Compact Single Stage Pressure Regulator

Recommended Industries: Chemical, Energy, Aerospace, OEM

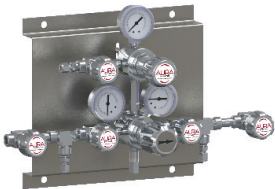

EXD Pressure Differential Switchover

Recommended Industries: Chemical, Oil and Gas, Energy, Aerospace, Pharmaceutical, Electronics/Photovoltaics, OEM



EXF High-Flow Single Stage Pressure Regulator

Recommended Industry: Chemical



EXH Single Stage High Pressure Regulator

Recommended Industries: Oil and Gas, Aerospace, Pharmaceutical, Electronics/Photovoltaics, OEM



EXS Sub -Atmospheric Single Stage Pressure Regulator

Recommended Industries: Oil and Gas, Electronics/Photovoltaics



EXT High Temperature Single Stage Pressure Regulator

Recommended Industries: Oil and Gas

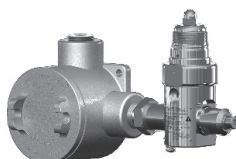
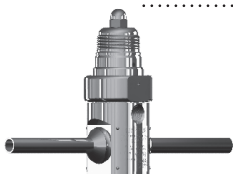

EXV Steam/Electrical Vaporizing Regulators

Recommended Industries: Oil and Gas

EX1



EX1 Series Single Stage Pressure Reducing Regulator

The AURA EX1 series is designed to regulate gas or liquid in one stage of pressure control for inlet pressures up to 6000 PSI. Pressure control is optimized by selecting the appropriate seat size and material for sensitive instrumentation sampling and process control applications. All stainless construction enables the EX1 to endure corrosive environments. Additionally, the EX1's low internal volume and 14-25 Ra surface finishes minimize reactivity and facilitate efficient purging.

EX1's Capsule® seat design ensures reliability under harsh conditions. Seat failure due to repetitive loading is eliminated by the Capsule®'s positive stop design. Proprietary machining provides surface finishes that yield 1×10^{-9} He ccs leak integrity. AURA's dual surface area diaphragm provides smooth sensitive pressure control, analogous to a multi-speed automotive transmission.

These features make the EX1 the right choice for critical applications.

FEATURES

Encapsulated seat

- High cycle life

Dual surface diaphragm

- Sensitive pressure control

High surface finish standard

- Low reactivity

SPECIFICATIONS

Design pressure

- Working pressure:
3000 PSIG PTFE
5500 PSIG PCTFE/PEEK
- Burst pressure:
> 4x Working pressure

Delivery options

- 0 to 15, 50, 100, 150, 250, 500 PSI

Flow Coefficient (Cv)

- .02, .06, .1

Material

- Chrome plated brass
- 316L SS body & 304 bonnet
- Inert and anti-corrosive LumiShield™ treatment

EX2

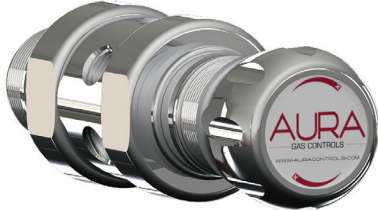

EX2 Series Two Stage Pressure Reducing Regulator

The AURA EX2 series is designed to regulate gas or liquid in two stages of pressure control for a maximum inlet pressure of 6000 PSI. The EX2's dual encapsulated seat design eliminates second stage seat failures by filtering particles generated during the assembly of peripherals and first stage parts. AURA's dual surface area diaphragm provides sensitive pressure control analogous to a multi-speed automotive transmission. The two stage design eliminates outlet pressure fluctuation associated with decaying inlet pressure conditions.

Front and rear threaded bonnets provide flexible panel mounting to minimize installation and piping costs. Complete assemblies minimize secondary assembly labor of peripherals such as gauges, fittings, valves and inlet connections.

These features make the EX2 the right choice for gas calibration standard and sample pressure control.

FEATURES

Dual encapsulated seat

- High cycle life

Front or rear panel mount

- Ideal for gas panels

Low internal volume

- Low reactivity

SPECIFICATIONS

Design pressure

- Working pressure:
3000 PSIG PTFE
5500 PSIG PCTFE/PEEK
6000 PSIG PEEK
- Burst pressure:
> 4x Working pressure

Delivery options

- 0 to 15, 50, 100, 150, 250 PSI

Flow Coefficient (Cv)

- .02, .06, .1

Material

- Nickel Plated Brass
- 316L stainless steel
- Inert and anti-corrosive LumiShield™ treatment

EXB



EXB Series Back Pressure Reducing Regulator

The AURA EXB back-pressure regulator provides sensitive excess pressure control via AURA's dual plane surface area diaphragm technology. Unlike standard pressure relief devices the EXB enables the engineer to throttle excess pressure from closed loop systems. The EXB will also accurately relieve spikes in system pressure caused by changes in instrument demand.

Available with a dual plane diaphragm up to 250 PSI and cartridge sensed to 1,500 PSI make the EXB flexible to meet most system applications. Two or four port configurations simplify piping layout making the AURA EXB back pressure regulator an engineer's first choice.

FEATURES

Dual plane diaphragm

- Sensitive pressure control

Dynamic cartridge sensed

- Enable higher settings

Low internal volume

- Minimize purging

SPECIFICATIONS

Design pressure

- Working pressure:
500 PSI
- Burst pressure:
> 4x Working pressure

Delivery options

- 0 to 15, 50, 100, 250, 500 PSI

Flow Coefficient (Cv)

- .17

Material

- Chrome Plated Brass
- 316L stainless steel
- Inert and anti-corrosive LumiShield™ treatment

EXC



EXC Series Compact Single Stage Pressure Reducing Regulator

The AURA EXC series incorporates a compact design to regulate gas or liquid phase in a single step with a maximum inlet pressure of 5,500 PSI. The 1.5" diameter body and 1 3/8" panel through hole enable the EXC to be integrated in instrumentation cabinet applications with ease. EXC's Capsule® seat design ensures seat reliability under harsh conditions. Seat failure due to repetitive loading is eliminated by the Capsule®'s positive stop design.

The EXC series will give the engineer multiple Cv options to meet both low and high flow requirements. Available in chrome plated brass or 316L, the EXC is an economical choice for calibration bottles or OEM equipment applications.

FEATURES

- 1 1/2" Envelope**
 - Minimize panel footprint
- Low internal volume**
 - Real-time process analysis
- No entrapment sites**
 - Maintain detector sensitivity

SPECIFICATIONS

- Design pressure**
 - Working pressure:
 - 3000 PSIG PTFE
 - 5500 PSIG PCTFE
 - Burst pressure:
 - > 4x Working pressure
- Delivery options**
 - 0 to 15, 50, 100, 500, 750, 1500 PSI
- Flow Coefficient (Cv)**
 - .02, .06, .08
- Material**
 - Chrome Plated Brass
 - 316L stainless steel
 - Inert and anti-corrosive LumiShield™ treatment available upon request

EXF



EXF Series High-Flow Single Stage Pressure Reducing Regulator

The AURA EXF series incorporates a balanced stem seat with a Cv of .8 for high flow applications requiring 1 to 250 PSI. Half inch (1/2") through ports as well as welded connections enables the EXF to be used in pipeline application in the pharmaceutical and chemical processing industries. AURA's large dual plane surface area diaphragm provides sensitive pressure control analogous to a multi-speed automotive transmission.

Available in chrome plated brass and 316L make the EXF an economical choice for critical high flow applications. Standard 14-25 Ra surface finishes minimize reactivity and facilitate efficient purging for blanketing applications. The dual o-ring rear seal enables the EXF to accept up to 3,000 PSI giving the engineer maximum flexibility and performance.

FEATURES

- Balanced stem seat**
 - Minimal decaying inlet pressure effect
- Low seat cracking pressure**
 - Low static loss
- Dual plane diaphragm**
 - Sensitive process control

SPECIFICATIONS

- Design pressure**
 - Working pressure:
 - 3000 PSIG PTFE
 - Burst pressure:
 - > 4x Working pressure
- Delivery options**
 - 0 to 15, 40, 120, 200, 250 PSI
- Flow Coefficient (Cv)**
 - .8
- Material**
 - Chrome Plated Brass
 - 316L stainless steel
 - Inert and anti-corrosive LumiShield™ treatment

EXH



EXH Series Single Stage High Pressure Reducing Regulator

The AURA EXH series incorporates a self-relieving valve that enables full range adjustment in closed looped systems. Unlike other designs, the AURA EXH utilizes high yield strength materials to ensure long life on load bearing components. These materials allow repeated adjustment without binding or failure for applications up to 10,000 PSI. EXH's Capsule® seat design ensures seat reliability under harsh conditions. Seat failure due to repetitive loading is eliminated by the Capsule®'s positive stop design.

Available in chrome plated brass and 316L make the EXH an economical choice for high pressure charging or test bench applications in the aerospace, hydrostatic, and oil field industries.

FEATURES

- Encapsulated seat**
 - High cycle life
- Dynamic cartridge sensed**
 - Enable higher outlet pressures
- High surface finish**
 - Low reactivity

SPECIFICATIONS

- Design pressure**
 - Working pressure:
 - 3000 PSIG PTFE
 - 5500 PSIG PCTFE
 - 6500 PSIG PEEK
 - Burst pressure:
 - > 4x Working pressure
- Delivery options**
 - 0 to 750, 1500, 2500, 4500, 6500 PSI
- Flow Coefficient (Cv)**
 - .02, .06, .1
- Material**
 - 316L stainless steel
 - Inert and anti-corrosive LumiShield™ treatment available upon request

EXS



EXS Sub-Atmospheric Single Stage Pressure Reducing Regulator

The AURA EXS series is a high purity single stage regulator designed to regulate pressure under sub-atmospheric conditions in addition to low flow and pressure applications. The proprietary hybrid spring design pushes up the diaphragm, allowing precision pressure control under vacuum and forward pressure from 0 PSIA-100 PSIG.

Additionally, the EXS's oversized dual surface diaphragm allows for increased sensitivity and control in low flow and low pressure applications. Constructed of 316L stainless steel and utilizing a 10 micron encapsulated seat, the EXS filters out significantly more damaging particles from the gas stream and is the engineers ideal choice for applications like biomedical analysis, hydrocarbon leak detection, and instrument calibration.

FEATURES

Encapsulated seat

- High cycle life

Dual surface diaphragm

- Sensitive pressure control

Hybrid spring design

- Operates under vacuum and forward pressure

Functional Specifications

Delivery options

- 0 PSIA to 50 PSIG, 0 PSIA to 100 PSIG

Flow Coefficient (Cv)

- .02, .06, .08

Leak rate

- External: 1×10^{-8} He ccs
- Seat: Bubble tight

Material

- 316L stainless steel
- Inert and anti-corrosive LumiShield™ treatment available upon request

EXT



EXT High Temperature Single Stage Pressure Reducing Regulator

The AURA EXT series is designed to regulate the pressure of gas or liquid at elevated temperatures. The EXT is available with threaded or welded connections to ensure system integrity.

EXT's capsule seat design ensures seat reliability under harsh conditions. Proprietary machining provides surface finishes that enable metal to metal seals. AURA's dual plane surface area diaphragm provides sensitive pressure control.

With six pressure ranges to 500 PSI and a maximum operating temperature of 550°F the EXT regulator is an ideal choice for furnace and refinery process applications.

FEATURES

Encapsulated seat

- Long life

550° MAX temperature

- Heat resistant

High load marginal spring

- No zero leaks

SPECIFICATIONS

Design pressure

- Working pressure: 3000 PSIG PEEK
- Burst pressure: > 4x Working pressure

Delivery options

- 0 to 15, 50, 100, 150, 250, 500 PSI

Flow Coefficient (Cv)

- .06

Material

- 316L stainless steel
- Inert and anti-corrosive LumiShield™ treatment

EXV

EXV Vaporizing Regulators

The AURA EXV series regulators are designed to heat a sample stream in order to maintain the gas phase into an instrument for analysis. Unlike other designs, the AURA EXV utilizes a labyrinth style flow path to maximize surface area for heat transfer. The EXV is available with either a steam or electrically heated module. The electric module has ATEX third party approval.

The EXV series offers the engineer maximum system flexibility with three heater options and six pressure ranges to 500 PSI. The EXV is the ideal choice for demanding fluid and hydrocarbon process analysis.

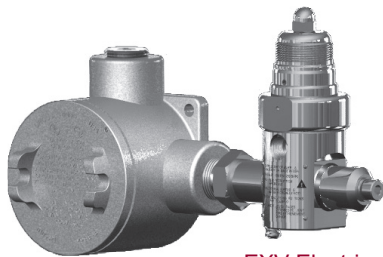

EXV Electrical

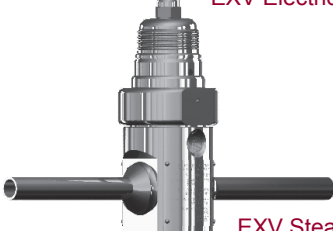

EXV Steam

FEATURES

Electric or steam

- Process flexibility

Thermistor service port

- Field repairable

High surface area

- Excellent heat transfer

SPECIFICATIONS

Design pressure

- Working pressure: 3000 PSIG PEEK
- Burst pressure: $\geq 4x$ Working pressure

Delivery options

- 0 to 15, 50, 100, 150, 250, 500 PSI

Flow Coefficient (Cv)

- .06

Material

- 316L stainless steel
- Inert and anti-corrosive LumiShield™ treatment

EXD

Pressure Differential Switchover System

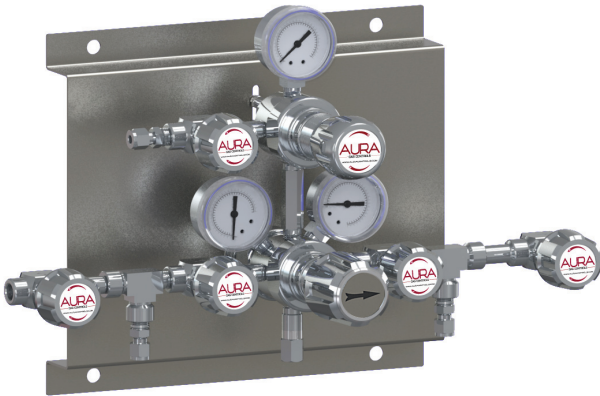

The AURA EXD series is an automatic switchover system designed to provide a continuous supply of high purity gas for inlet pressures up to 3000 PSI. The proven pressure differential technology enables fail safe operation with simple priority valve assignment. Consistent outlet pressures, available in six ranges up to 350 PSI, are achieved with the integral line regulator.

Additionally, the EXD's proprietary machining provides superior surface finish of 14-25 Ra that yields a 1×10^{-9} He ccs leak integrity. The EXD's optional inlet purge or shutoff valve assemblies provide low internal volumes and reduced leak paths that allow for a more efficient purging process. Available with either a 4" or 12" panel, the AURA EXD allows for maximum flexibility and superior functionality as the engineer's first choice for instrument applications requiring uninterrupted supply of high purity gases.

Features

EX1 series integral line regulator

- Encapsulated seat design

Low internal volume

- Enables efficient purging

Dual surface diaphragm

- Sensitive pressure control

Specifications

Working pressure:

- 3000 PSIG

Burst Pressure:

- 4X Working pressure

Delivery options

- 0 to 15, 50, 100, 200, 350, 150 PSI.

Flow Coefficient (Cv)

- .06

Material

- 316L Stainless Steel
- Inert and anti-corrosive LumiShield™ treatment available upon request



For harsh environments requiring the safe handling of corrosives, processes demanding analytical efficiency, and applications where maintaining process purity is critical, AURA Controls' new LumiShield™ products are vital to ensuring optimum system performance, component longevity, and process integrity.

Typical industries:

- Refinery/Petrochemical
- Chemical Processing
- Energy/Stack gas testing
- Biopharm
- Photovoltaic
- Research
- Oil & Gas exploration/Offshore platforms

LumiShield™ products are produced through a chemical vapor deposition process that applies a proprietary blend of carbon and silicon in depth that bonds with the crystal structure of 316L SS, making it part of the base metal. The result is an extremely flexible and wear resistant metal with superior corrosion resistance and chemical inertness to stainless steel or exotic metals even at temperatures as high as 400 degrees C and pH ranges 0-14.

Typical applications:

- Stack gas monitoring/CEMS systems
- Mercury analysis
- NOx and SOx monitoring
- HCl analysis
- NH3 emissions monitoring
- Hydrocarbon analysis
- GC testing of active components
- Photovoltaic wafer production
- Low moisture sampling & control
- Reduced sulfur analysis

The LumiShield™ treatment creates a flexible, wear-resistant and inert surface that provides superior corrosion resistance to 316L stainless steel and exotic metals.



LumiShield's inert surface eliminates absorption of corrosive compounds and moisture making it an ideal choice for harsh environments and sensitive analytical systems.

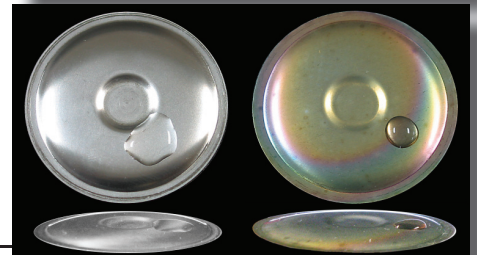



AURA

— GAS CONTROLS —



AURA Gas Controls

800.582.2565 • info@auracontrols.com

www.AURACONTROLS.com

ADC3180E